

NOTES:

1. NEMA 1 CONSTRUCTION.
2. BUS BARS SILVER PLATED COPPER - 98% CONDUCTIVITY
3. BOX SHALL HAVE NAME PLATE WITH MANUFACTURER'S NAME.
4. FRONT DOORS SHALL BE SEALABLE & LOCKABLE.
5. ALL NUTS, BOLTS, FLAT WASHERS AND BELLEVILLE WASHERS SHALL BE NON MAGNETIC STAINLESS STEEL PER PSEG SPEC.
6. PHASES HAVE 1/4"-20 TAPPED HOLE BELOW AND ABOVE CT SHELF FOR NEUTRAL LUG.
7. LINE (TOP SIDE) & LOAD (BOTTOM SIDE) CLEARLY MARKED.
8. EXIT AND ENTRY PERMITTED THROUGH TOP, BOTTOM, SIDE AND REAR OF CABINET WITH PROPER REFERENCE OF NEC WIRE BENDING SPACE REQUIREMENTS.
9. NEUTRAL BONDING KIT AVAILABLE UPON REQUEST.

10.75 MIN
BETWEEN PHASES

6.00
MIN

6.00
MIN

6.00
MIN

PART #	AMPS	BUS WIDTH (IN)	BUS LEAVES	SETS - LINE & LOAD (500MCM)
NAV-NJ-CT-10	1000	4	1	3
NAV-NJ-CT-12	1200	5	1	3
NAV-NJ-CT-16	1600	4	2	4
NAV-NJ-CT-20	2000	4	2	5

B

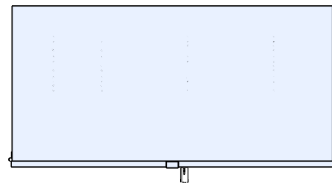

TOP VIEW

PADLOCKABLE
FRENCH DOOR
WITH 3 PT CATCH

NON LIFTING
HINGES FACTORY
INSTALLED

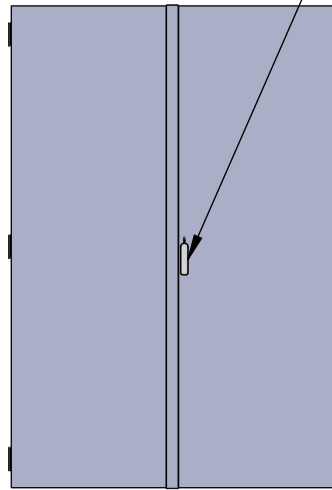

FRONT VIEW CLOSED

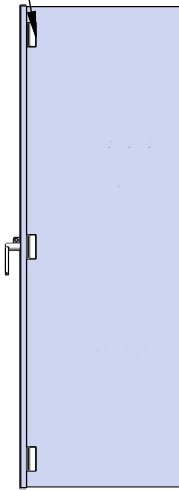

SIDE VIEW

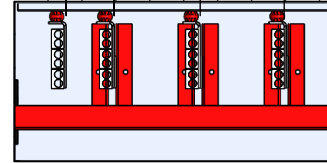

TOP VIEW SECTIONED

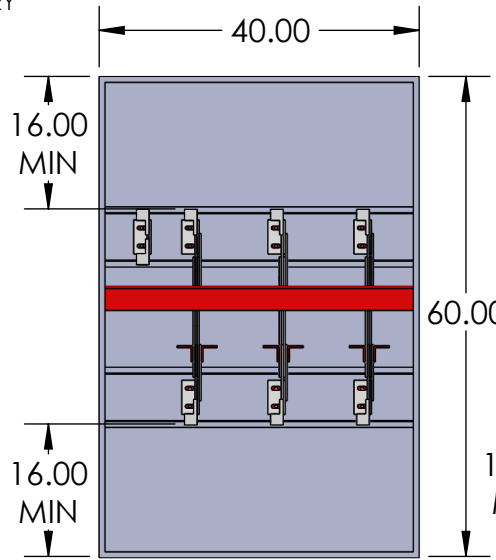

FRONT VIEW OPENED

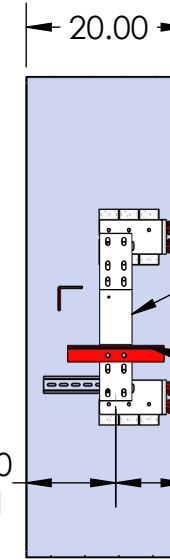

SIDE SECTIONED VIEW

GLASTIC
CT WIRING
SUPPORT

PT FUSE
HOLDER

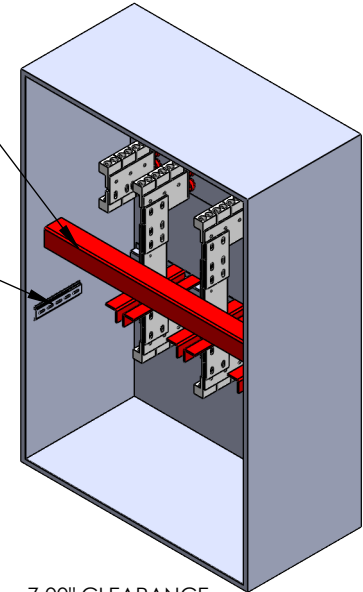

7.00" CLEARANCE
FOR REMOVABLE
LEAVES

GLASTIC
CT MOUNT

A

A

NAME	DATE
N. BOSETTI	9/10/2025
DRAWN BY	
REVIEWED BY	

NAV-TECH
INCORPORATED

155 MARCUS BLVD
HAUPPAUGE, NEW YORK 11788
PH: (718) 257-2111 FAX: (718) 257-2626

MAT'L:	12 GAUGE GALV STEEL
FINISH:	GRAY POWDER COAT ANSI 61
WEIGHT:	
ALL DIMENSIONS ARE NOMINAL UNLESS EXPLICITLY STATED OTHERWISE	

DRAWING TITLE:	PSEG NJ 1000A-2000A CT CABINET OVERALL SPEC
PART #:	NAV-NJ-CT-XX
DO NOT SCALE DRAWING	

DESCRIPTION:	NEMA 1 377 CT CABINET 1000A-2000A 600V MAX PSEG NJ APPROVED WINDOW CT CABINET				
SCALE:	1:24	SIZE	A	SHEET	1 OF 1
REV.	2				